

B-B ( 1 : 1.5 )

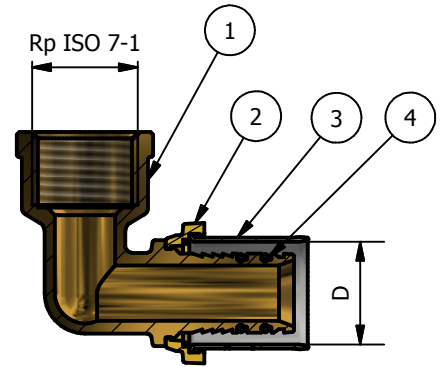
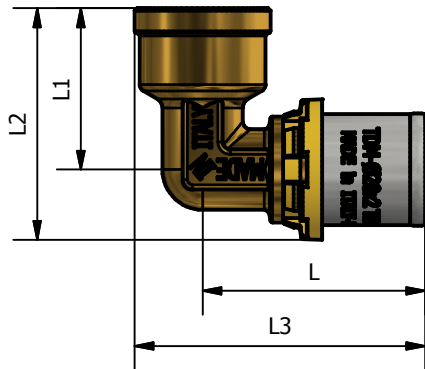

TDM CODE	SIZE	Rp	D	L	L1	L2	L3
1770 1216	1/2x16	1/2	16x2	45,5	30	42	59
1770 1218	1/2x18	1/2	18x2	45	32	43	58,5
1770 1220	1/2x20	1/2	20x2	45	32	44	58,5
1770 3420	3/4x20	3/4	20x2	48	35	49	64,5
1770 3425	3/4x25	3/4	25x2,5	51	37	54	67,5
1770 3426	3/4x26	3/4	26x3	51	37	54	67,5
1770 0125	1"x25	1"	25x2,5	54	43	60	75
1770 0126	1"x26	1"	26x3	54	43	60	75
1770 0132	1"x32	1"	32x3	55	43	63	75

N°	DESCRIPTION	MATERIAL
1	BODY	CW 617N EN 12165
2	INSULATION RING	NAYLON 6 (Yellow)
3	BUSH	AISI 304 EN 10088-2
4	O-RING	NBR 70

WORKING PRESSURE MAX FOR GAS	0,5 BAR
WORKING TEMPERATURE MIN- MAX FOR GAS	-15°C/50°C
WORKING PRESSURE MAX FOR WATER	10 BAR
WORKING TEMPERATURE MIN- MAX FOR WATER	-0°C/80°C

CONFORMITY
1) DM 37 del 22/01/2008
2) UNI/TS 11343
3) UNI/TS 11344
4) UNI EN 10226-1 (ISO 7-1)
5) UNI EN 681-1
6) UNI EN 682

01	Cambiato o-ring da HNBR giallo a NBR nero acqua/gas	Delaini M.	23/03/2018
00	Prima emissione	Delaini M.	27/04/2012
Rev.	Nota Revisione	Approvatore	Data Approvazione
Toll Gen:	JS14	Stato sup.:	Giallo Sabbiato
Filetto:	ISO 7-1	Note tecniche:	
Peso lavorato:		Peso grezzo:	
		N° stampo:	
Materiale:		Disegnatore:	Data: 27/04/2012
		Delaini P.	
TDM Brass s.r.l via Artigiani , 7-9 25030 Maclodio BS Italy tel +39 030 9972217 fax 030 9787089 www.tdmbrass.it email info@tdmbrass.it			

Codice: 1770 scheda

Descrizione: Female elbow fitting

**TDM** BRASS  
Italian Fittings